

# Dispenser (ET Stand)

● For E-Rings stacked on rail  
(ETSK-1 or below)

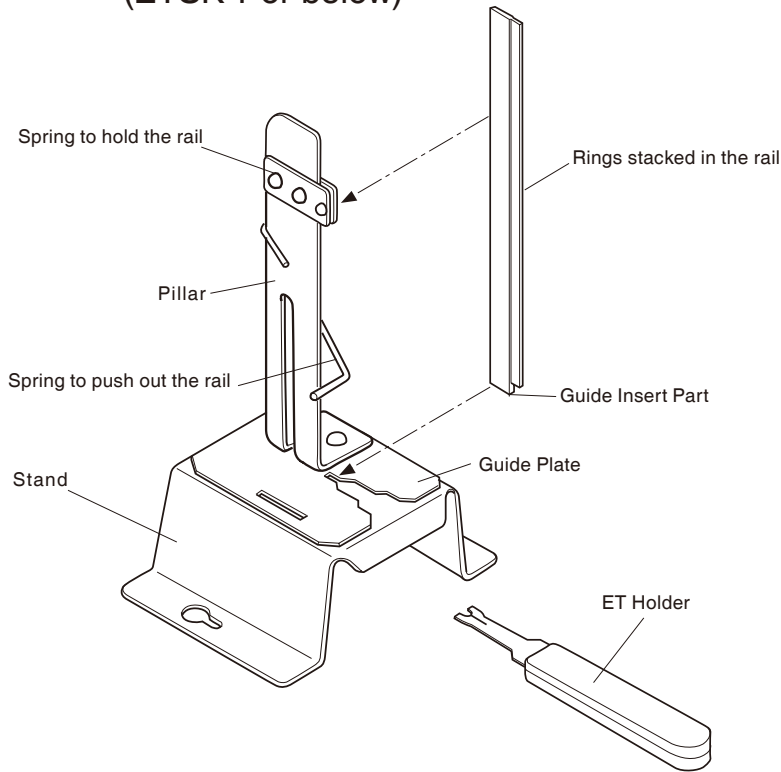

● For E-Rings stacked with tape  
(ETSK-1.2 or above)

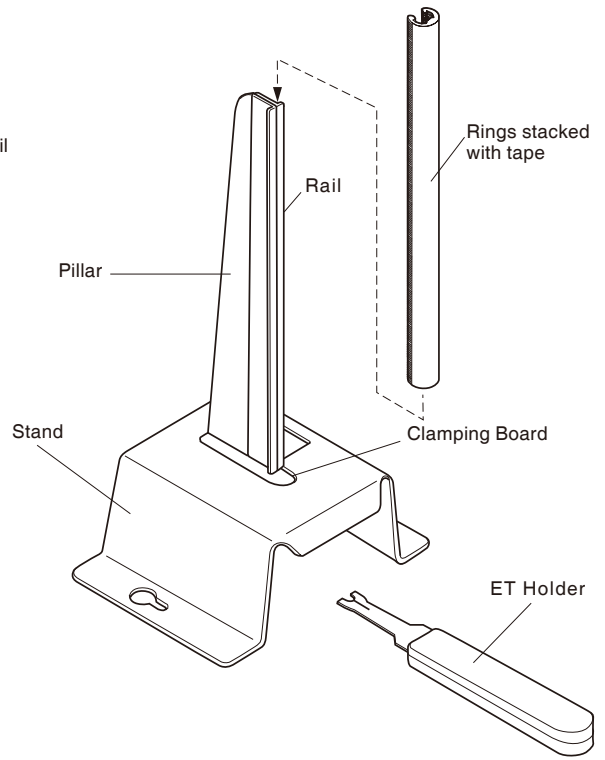

Size chart of Stacked E-Ring and ET Holder used in Dispenser (ET Stand)

Unit:mm

Size No.	Applicable Size of E-Ring			ET Stack Size No.	ET Holder Size No.	Dispenser (ET Stand) Size No.
	Diameter of inner periphery	Diameter of outer periphery	Plate thickness			
ETW- 0.6	0.6	1.5	0.2	ES- 0.6	ETH- 0.6	ETSK- 00
0.7	0.67	2	0.2	0.7	0.8	00
0.8	0.8	2	0.2	0.8	0.8	00
1	0.98	2.8	0.2	1	1	1
1.2	1.2	3	0.3	1.2	1.2	1.2
1.5	1.5	4	0.4	1.5	1.5	1.5
1.9	1.9	4.5	0.4	1.9	1.9	1.9
2	2	5	0.4	2	2	2
2.3	2.3	6	0.4	2.3	2.5	2.5
2.5	2.5	6	0.4	2.5	2.5	2.5
3	3	7	0.6	3	3	3
3.2	3.2	7	0.6	3.2	3	3
4	4	9	0.6	4	4	4
5	5	11	0.6	5	5	5
6	6	12	0.8	6	6	6
7	7	14	0.8	7	7	7
8	8	16	0.8	8	8	8
9	9	18	0.8	9	9	9
10	10	20	1	10	10	10
12	12	23	1	12	12	12

RETAINING RINGS | PUSH NUTS | WAVE WASHERS AND OTHERS | SCREW TYPE PLATE NUTS | SPRING PINS | SNAP PINS | JOINT CLIPS

ASSEMBLY TOOLS